



VAVA Voom20 Bluetooth® Speaker

ONLINE GUIDE

Model NO.: **VA-SK002**

1. Package Contents

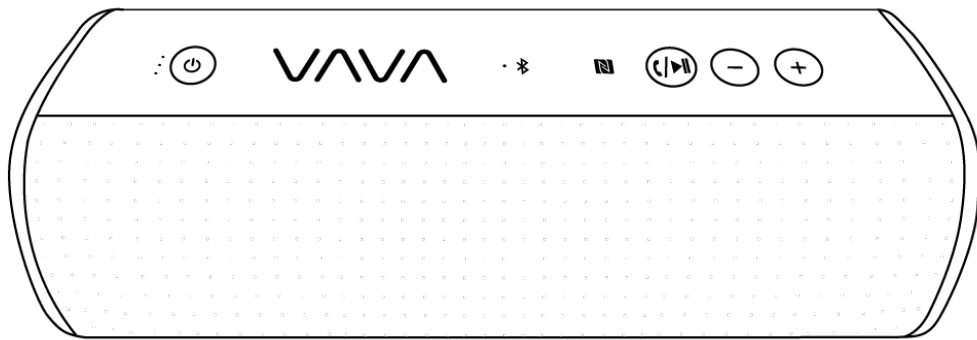

VAVA Voom20 Bluetooth® Speaker

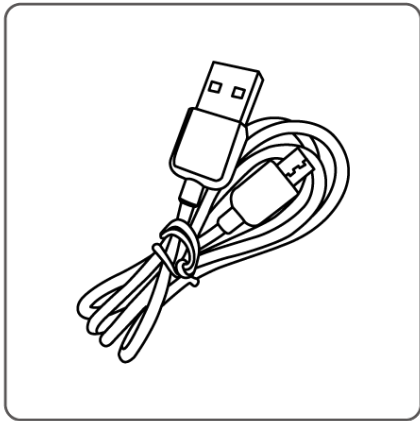

1 x Micro-USB Cable

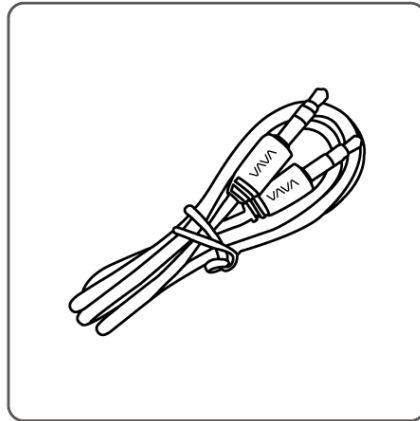

1 x 3.5 mm Audio Cable



1 x User Guide

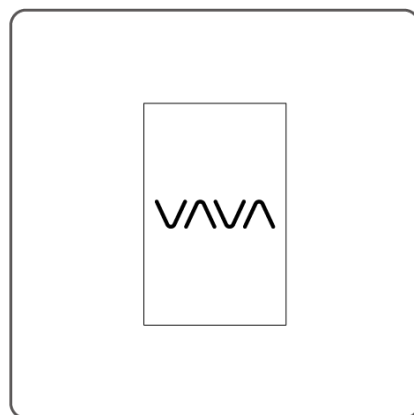

1 x Travel Pouch

2. Speaker Overview

Top View

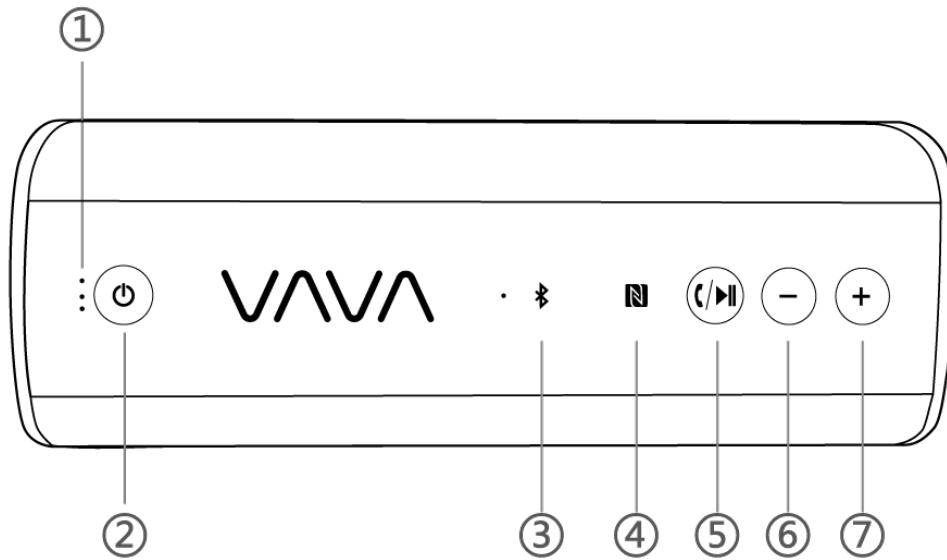



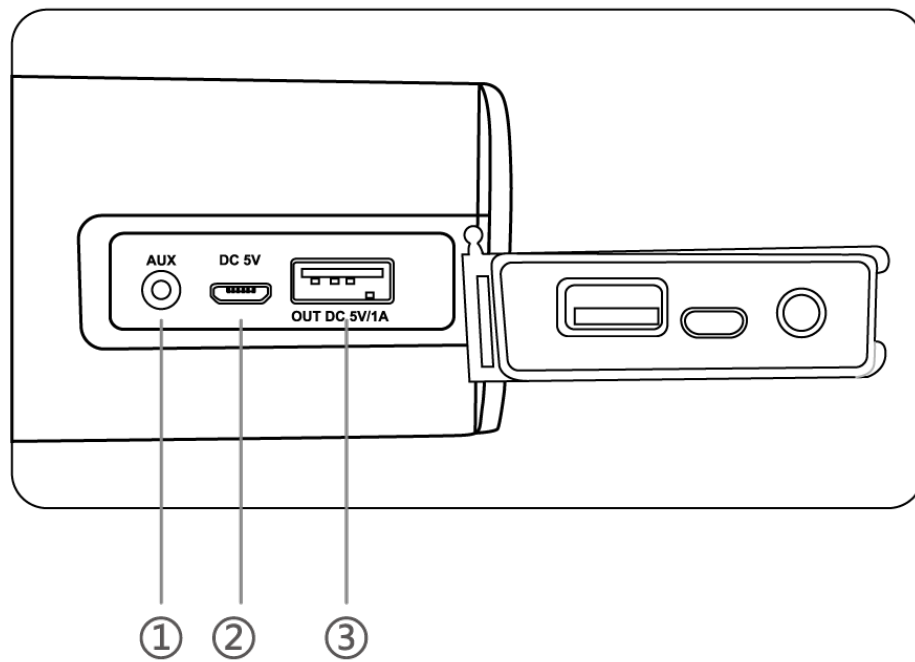

- ① Battery Indicator
- ② Power Button
- ③ Bluetooth Indicator
- ④ NFC
- ⑤ Play / Pause Button
- ⑥ Volume – Button
- ⑦ Volume + Button

Back View



- ① AUX Port
- ② Micro-USB Charging Port
- ③ USB Output 5V / 1A

3. Control Functions

Button	Function	Operation
 Power	Power on/off	Press and hold for 2 seconds
	Check battery level	Press once
 Play / Pause	Play / Pause	Press once when music is playing / paused
	Mute	When in AUX mode, press the play / pause button to mute
	Answer phone call	Press once when a call is incoming
	Hang up	Press once during a phone call
	Reject phone Call	Press and hold when a call is incoming
	Redial	Double press
	Reset Bluetooth® connection	Press and hold for 3 seconds, a voice prompt will inform you of a successful reset
Clear pairing history	Press and hold for 10 seconds or until you hear a double beep	
 Volume +	Volume +	Press once
 Volume -	Volume -	Press once

Note: When the volume reaches the maximum or minimum level, the Bluetooth® Indicator will flash once.

4. Charging

You can charge the speaker by using the Micro-USB charging cable to connect with any USB power adapter. Please make sure the USB power adapter has a current output of at least 1A.

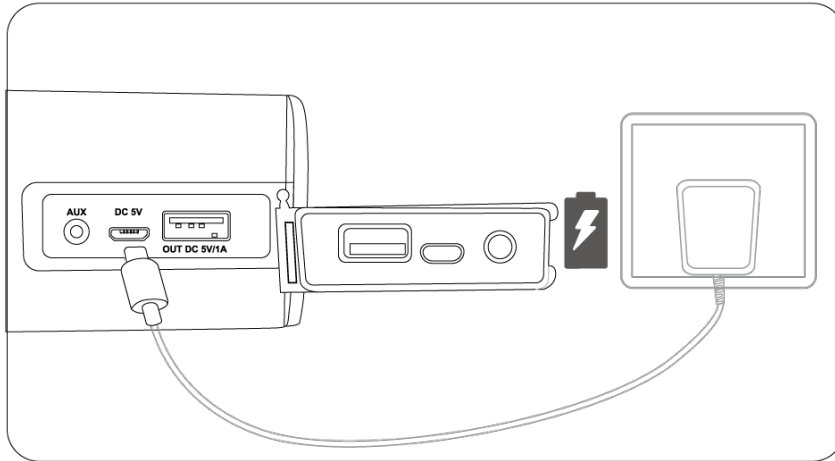

5. Power On / Off

Press and hold the Power Button for 2 seconds to turn the speaker on or off. When powered on, the speaker will attempt to connect with the previously paired device. Otherwise, it will enter pairing mode and the Bluetooth® Indicator will start flashing.

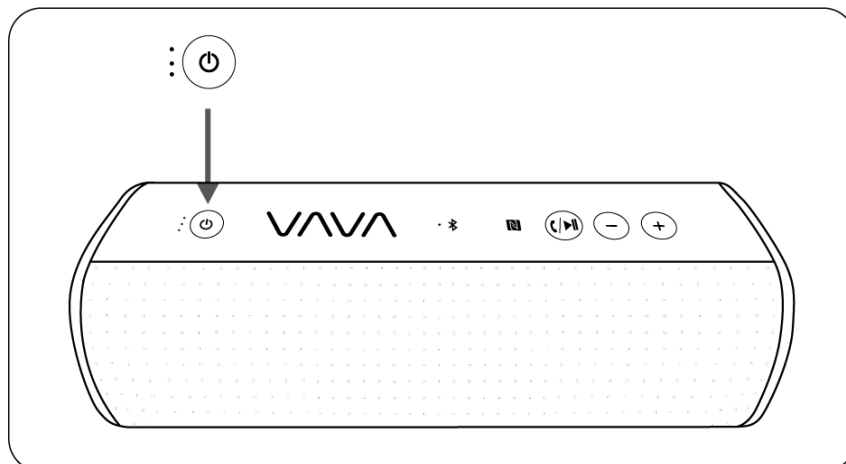

6. Battery Level

Press the Battery Indicator once to check the remaining battery level.

3 LEDs	67 – 100% battery
2 LEDs	33 – 66% battery
1 LED	1 – 32% battery

Note: When the battery is low, the Battery Indicator will start flashing and the speaker will beep.

7. Bluetooth® Pairing

To pair with any Bluetooth device:

- Power on the speaker.
- Wait for the Bluetooth® Indicator to start flashing.
- Turn on the Bluetooth® function from your device and searching for nearby connections.
- Select the “VAVA VOOM20” from the search results and tap to connect.
- The Bluetooth® Indicator will stop flashing and stay on to indicate a successful connection.
- If a pass code is required, please use “0000”.

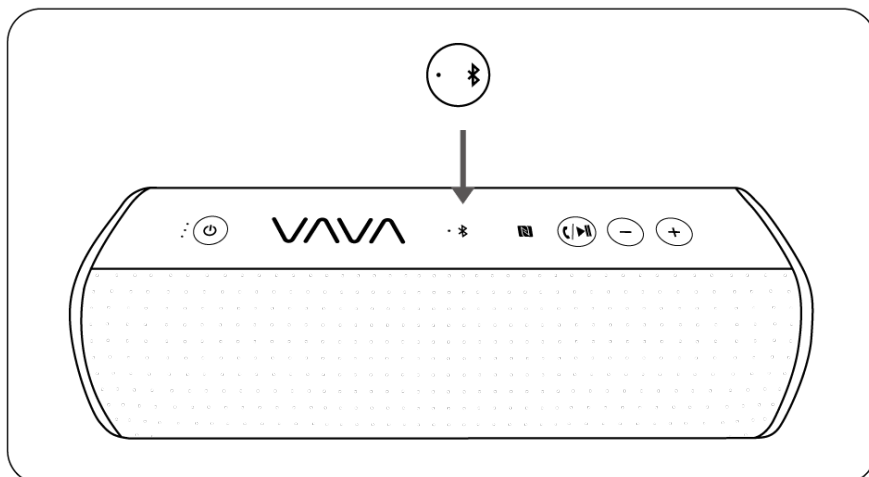

8. Pairing Two Devices

You can pair the speaker with two devices at the same time. This enables you to quickly switch devices without going to pairing mode every time. To pair with two devices:

- Follow the “Bluetooth Pairing” instructions to pair the speaker with the first device.
- Turn off the Bluetooth function on the first device and the speaker will go into pairing mode automatically.
- Pair the second device with the speaker.
- Go back to the first device and turn on the Bluetooth function. Select “VAVA VOOM20”, now both devices are paired.
- To switch between the two devices, pause the music on one device and start playing on the other.

9. NFC Connection

NFC will let you pair the VAVA Voom20 with another NFC-supported device easily and instantly.

- Make sure NFC is enabled on your device.
- Gently touch the NFC zone on your device against the NFC zone on the speaker.

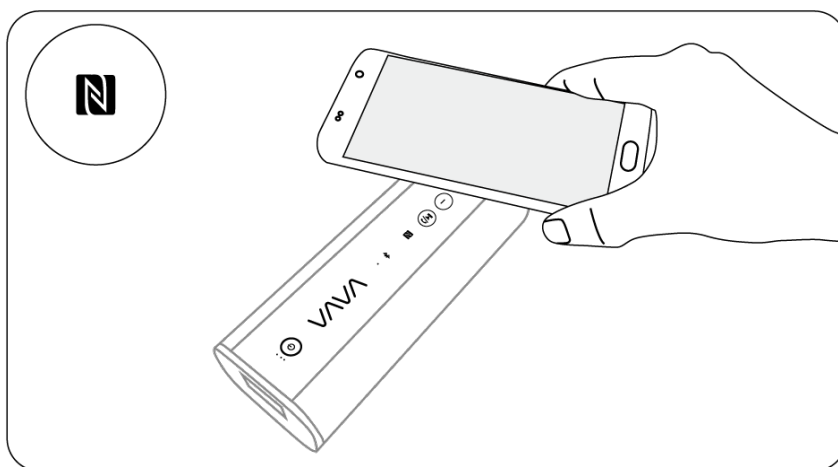

10. 3.5 mm AUX Connection

If Bluetooth® is not available, you can connect to other music devices via a 3.5 mm AUX cable.

Note: When connected in AUX mode, the Bluetooth® connection is temporarily disabled. The built-in microphone on the speaker will not work with AUX connection.

11. Charging Smartphones

You can charge your phone by connecting it to the speaker USB output port. Press the Power Button to start charging.

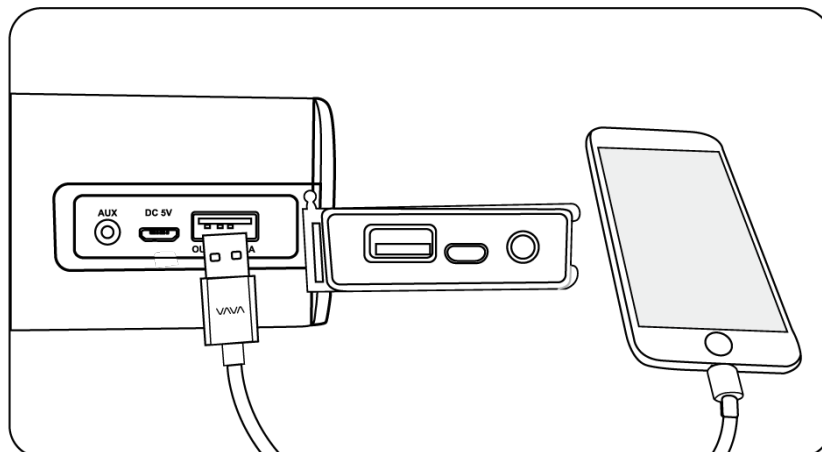

12. Troubleshooting

Q: Why can't my device find "VAVA Voom20" when searching for Bluetooth® connections?

A: Please make sure the speaker is in pairing mode with the Bluetooth® indicator flashing. If the Bluetooth® indicator is solid, press and hold the play/pause button for 3 seconds to reset the Bluetooth® connection. Also, make sure the speaker is close to your device.

Q: Why is the music intermittent in Bluetooth® mode?

A: Bluetooth® is a radio technology that is sensitive to objects between the speaker and the connected device. Ensure the speaker and the connected device is within range and in direct line of sight.

Q: I tried to connect to the VAVA Voom20, but my device says "connection failed"?

A: Please make sure:

- Your device supports the Bluetooth® stereo profile "A2DP".
- Try to clear the speaker pairing memory by pressing and holding the play / pause button for 10 seconds.
- Delete "VAVA Voom20" from your device search results and connect again.

13. Care and Caution

- Keep away from heat; avoid extended exposure under direct sunlight. High temperatures will shorten the lifespan of the speaker.
- Do not try to take the product apart, it may cause serious damage.
- Do not drop or knock your speaker on hard surfaces as it may damage the interior circuitry.
- Do not use chemicals or detergents to clean the product.
- Do not scrape the surface with sharp objects.

14. Specifications

Bluetooth® Version	V4.0+EDR
Bluetooth® Profiles	A2DP, AVRCP, HSP, HFP and AAC
Audio Codex	aptX
Microphone	Omni-directional
Driver	2 x 2 inch full-range drivers
Range	Up to 33ft / 10m
Battery life	Up to 10 hrs
Charging Power	5V/1.5A
Charging Time	6 hrs
Waterproof Rating	IPX5
Operating Temperature	14 to 113 °F / - 10 to 45 °C
Storage Temperature	- 22 to 140 °F / - 30 to 60 °C
Weight	1.53 lb / 694 g
Dimensions	7.58 x 2.81 x 2.38 in / 19.25 x 7.15 x 6.05 cm

15. Support and Inquiry

For further inquiries and technical support, please email us at **support@vava.com** with details. Or visit our website at **www.vava.com**. We normally respond to inquiries within 24 hours.



www.vava.com

NORTH AMERICA

E-mail: support.@vava.com

Tel : 1-888-456-8468 (Monday-Friday: 9:00 – 17:00 PST)

Address: 46724 Lakeview Blvd, Fremont, CA 94538

EUROPE

E-mail:

support.uk@vava.com(UK)

support.de@vava.com(DE)

support.fr@vava.com(FR)

support.es@vava.com(ES)

support.it@vava.com(IT)

EU Importer: ZBT International Trading GmbH, Lederstr 21a, 22525
Hamburg, Deutschland

ASIA PACIFIC

E-mail : support.jp@vava.com(JP)

FCC Compliance

This device complies with Part 15 of the FCC Rules. Operation is subject to the following two conditions: (1) This device may not cause harmful interference, and (2) this device must withstand any interference received, including interference that may cause undesired operation.

